

FHB0.5AT Series High-temperature Switching Regulator

Features:

- : Working temperature: ambient temperature: $-55^{\circ}\text{C} \sim +175^{\circ}\text{C}$ and max. shell temperature: $+185^{\circ}\text{C}$
- : Size: L:19.1×W:12.4×H:8.0mm
- : Input range: 4.5~36.0V
- : Output voltage: 1.25V, 1.5V, 1.8V, 2.5V, 3.3V, 5.0V, 6.0V, 7.0V, 8.0V, 9.0V, 10.0V, 12.0V, 15.0V, 24.0V
- : Output current: 0.5A
- : 1.8mA static working current
- : 5uA cut-off holding current
- : Adjustable terminal with output cut-off and output voltage
- : Conversion efficiency: 70%-96%
- : Working frequency: 300KHZ
- : Sealed metal casting: impact and moist resistance and electromagnetic radiation protection
- : Provide rated power without deduction at 185°C (shell temperature)
- : Over-voltage and over-current failure switch-off delay restart

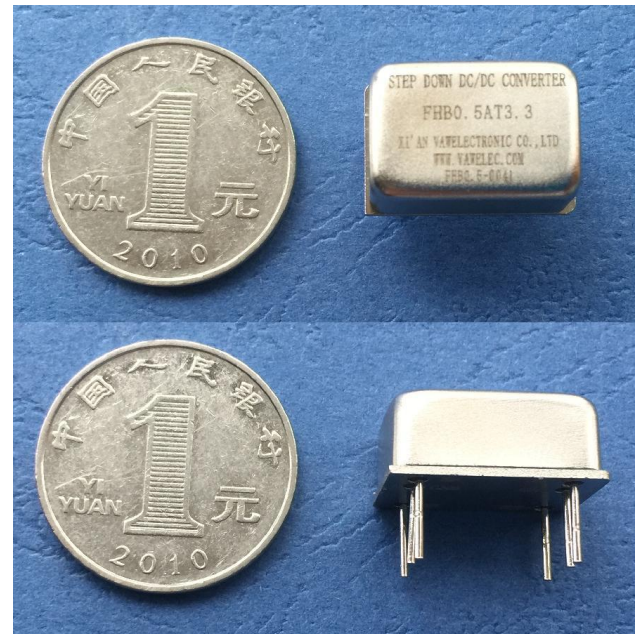

Description:

FHB0.5AT series high-temperature switching regulators outputting current 0.5A are specially designed for electronic equipment working in the harsh environment and can continuously work for 10,000 hours at shell temperature 150°C , for 1,000 hours at shell temperature 185°C . With features of being resistant to high temperature, impact and humidity, it is particularly suitable for being used as power supply system for petroleum prospecting logging tool, petroleum drilling instrument, geophysical detecting instrument, vehicles, telecommunication, network infrastructures, enterprise and high-performance calculation, etc. It can substitute analog 42094 series and 42095 series high-temperature resistant 3-terminal voltage regulator.

FHB0.5AT series switching regulators' range of input voltage is 4.5V~36.0V and the output voltage allows to be positive and negative. The range of output voltage's absolute value is from 1.25V to 85% of input voltage. It provides non-isolated single-way fixed voltage or 0.5A current output of adjustable voltage. When the output is 24V, it will output 10W power. Within the entire range of working temperature and conversion between full load and no-load, the output voltage fluctuation is within 0.1V.

FHB0.5AT series switching regulators are mostly suitable application in battery power supply system requiring non-isolation between input and output and low power consumption. Its static working current is not greater than 2mA. If it needs to be cut off, the holding current after cut off will be reduced to 50uA.

FHB0.5AT's output voltage adopts feedback control and it remains stable in any condition. Therefore, it is possible

to connect it to auxiliary output of multi-output power module so as to conduct secondary regulation on auxiliary output voltage. This will make each output of multi-output power module stable and precise.

FHB0.5AT has output adjusting terminal ADJ which can be used to adjust output voltage. The picture on the right shows the internal adjusting circuit. During adjustment, it requires to always ensure the voltage at connection points R1 and R2 to be 1.25V. Before delivery, we have adjusted R1, making the output voltage rated value in condition that ADJ is suspended. The error is $\pm 50\text{mV}$. ADJ is directly connected to GND and the output is maximum. ADJ is directly connected to VOUT and the output is minimum. In practical use, due to line voltage drop and plug-in loss, voltage should be less than rated value in application. Thus if circuit requires precise voltage, it needs to output by fine adjustment. During adjustment, R3 should be connected to a proper resistor in series and then connected to VOUT or GND so as to make output voltage reach the rated value at component terminal. If user needs modules with different output voltages, to reduce the ordering category, it only needs to order the one with the most requirements. The rest can use this ordered type to adjust for output.

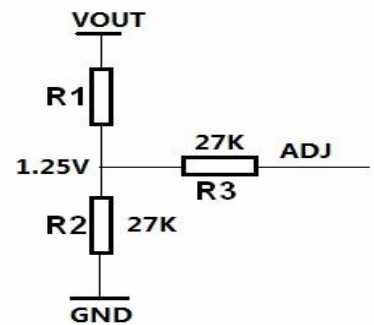

图一

FHB0.5AT's EN terminal is a multi-function interface which can define the module's soft start time or restart time after overcurrent protection when it connects a capacitor against the ground. If EN terminal against the ground is capacitor C_{ss} , chip's internal power supply is V_t , then the soft start time $T_{ss} = 100 \times C_{ss} \times \ln[V_t / (V_t - 1.4)]$. In this formula, start time T_{ss} is measured in second and C_{ss} in F. 150NF is already internally connected. Its value is the sum of internally connected capacitor and externally connected capacitor. V_t is powered by chip. When input voltage is lower than or equal to 8.0V, it equals input; when input is higher than 8.0V, power supplied by chip is limited to 8.0V. During normal operation, the level of EN terminal charges and discharges above 150MV. If its electric potential is reduced to be lower than 150MV, the entire module will cut off and enter the maintaining status. For this reason, it can be used as a cut-off enabling terminal to realize suspended enabling output and low level cut-off output. This is favorable to low power consumption system to cut off the system that does not work in some conditions so as to save the input power. The typical power consumption after cut off is only 50uA. If it is unnecessary to be cut off, it only needs to suspend EN terminal. If it is necessary to be cut off, just connect it to the ground. Therefore, when the module is in normal operation, besides that EN terminal is externally connected to a capacitor, cut-off controlling circuit requires to be connected with its high impedance. Normally, EN terminal connects to D of MOSFET, S is connected to the ground and D is connected to control level. High control level makes EN connected against the ground and module cut off.

FHB0.5AT contains output short circuit and overload automatic cut-off circuit. In condition that EN terminal does not connect capacitor, when output exceeds 1.0A for 50ms, the module cuts off output. When overcurrent fault is removed, it automatically resumes output voltage. The capacitor externally connected to EN terminal will make the above protection time extend to T_{ss} .

FHB0.5AT's shell temperature is up to 185°C. In condition that its heat does not exceed 0.3W, the heat cooling is thus unnecessary at ambient temperature 175°C. As it is non-isolated step-down module, its heating amount is not higher than 0.3W, which covers the most working conditions of this module.

The higher the voltage that the module outputs, the less the difference value between input and output will be, and the conversion efficiency will be higher. The efficiency reaches 96% when inputting 30V and outputting 24V and 89% when inputting 5V and outputting 3.3V.

FHB0.5AT's working frequency is up to 300KHZ which provides a good filtering condition. But as the module can normally work at the maximum shell temperature 185°C and the module itself emits heat, which makes the module mostly works at ambient temperature 175°C. As capacitor does not emit heat and its price and size rise sharply along with the rise of temperature. For this reason, we externally connected filtering capacitor needed by power module's input and output. In this case, it is possible to reduce the capacitor's temperature grade from 225°C temperature-resistant grade to ambient temperature-resistant grade, which can largely reduce its size and cost without affecting the use. This design requires that input and output to be connected with a capacitor when the module is used. The capacitor requires being much closer to the module. In normal condition, capacity of 22uf~100uf is connected at input terminal and capacitor of 68uf~330uf is connected at output terminal. The bigger the capacitor's capacity is, the better the performance of module's parameters will be. If the current is small in actual use, input and output capacitor can be properly lessened. In condition that it meets application, its output voltage ripple is typically smaller than 50MV. Within the entire temperature range, the temperature stability of frequency is ±10% and temperature drift of output voltage is 50 PPM/°C.

FHB0.5AT is a step-down voltage regulator adopting DC-DC-BUCK circuit. It starts to work when input is greater than the range 4.0-4.5V. After working, if input voltage is lower than output set voltage, it becomes a series resistor with internal resistance being 0.25Ω at most. When working steadily, smaller the voltage difference between input and output is, the higher the converting efficiency will be.

FHB0.5AT contains under-voltage cut-off functions, which enables the converter to stop working when the input voltage is less than 4.0V for the purpose of protecting the converter.

FHB0.5AT's shell is suspended and its isolation with input and output is greater than 500V. Normally, it is free of consideration, but if the shell is connected to input and output GND or electrically connected to AC current via a capacitor, its state in complex condition shall be more stable. The capacitor's capacity uses 1000PF-10000PF when it is connected to AC current.

Key components used for FHB0.5AT completely passed the in-factory test in strict accordance with the national military product quality standard. The factory test includes 24~72-hour live aging and screening under the temperature of +175°C. All finished products have experienced 4-hour full-load operation under the temperature of +204 °C before delivery so as to fully check the damage to the components during the production process and hence ensure the reliability of products.

Type Selection:

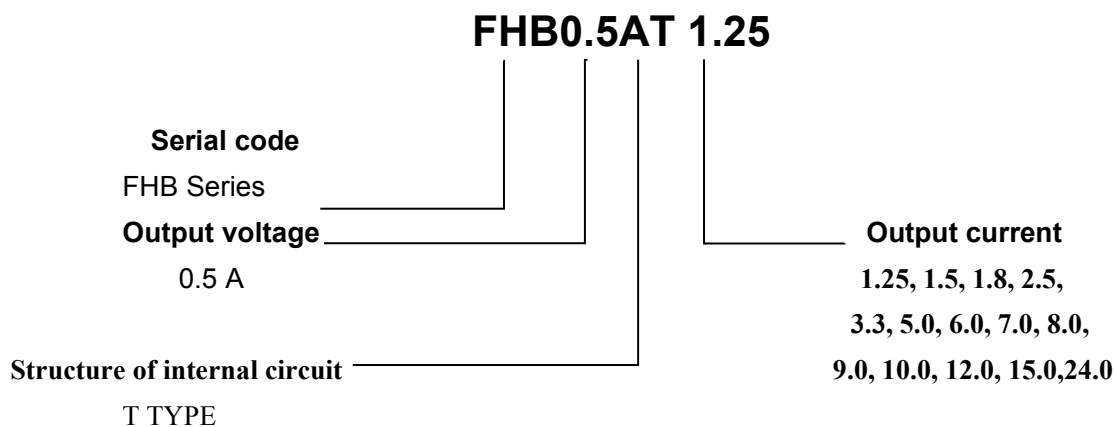

Technical Parameters

Item	Description	Value			Unit
		Min	Typical	Max	
Working temperature	Shell temperature of converter	-55		+185	°C
Input voltage		4.5		36.0	V
Output voltage	Able to output the following 1. 25V, 1. 5V, 1. 8V, 2. 5V, 3. 3V, 5. 0V, 6. 0V, 7. 0V, 8. 0V, 9. 0V, 10. 0V, 12. 0V, 15. 0V, 24. 0V	1.25V		24.0V	V
Size	Error: ±0.5mm	L:W:H:19.1*12.4*8.0			mm
Input current	V _{in} = 24.0V, I _{LOAD} =0mA, v _{out} =5.0V	1.8		3.0	mA
Output current		0		500	mA
Output ripple	Connect 22uf and 68uf capacitors for input and output		50	100	mVp-p
Output internal resistance	TC = +25°C	0.15		0.25	Ω
Output temperature drift			40		ppm/°C
Precision of output voltage	TC = +25°C	-0.05		+0.05	V
Output efficiency		70	90	96	%/
Undervoltage lock		4.0	4.25	4.5	V
On/off frequency			300		kHz
Cut-off current	EN=0V, V _{in} =24.0V			50	uA
Linear adjusting rate	V _{in} =4.5V to 36.0V		0.10		%/V
Loaded adjusting rate	I _{LOAD} =500mA		0.0002		%/mA
Voltage of EN terminal	Suspended operation				
	Low level cut off	-0.3		0.15	V
Input current of EN terminal				-50	uA
Output short-circuit current			1.0	1.5	A
Vibration	MIL-STD-810D Method 514.3	Each axis circulates for 10 times Frequency:20-50Hz/50Hz-2KHz, Amplitude/rate: 0.5mm/10g			OK
Shock	MIL-STD-810D Method 516.3	Shock three times for each Spike rate: 100g Holding time: 6ms			OK

Service Requirement:

The shell of the module is isolated from the input and output. During the use, it is directly mounted on printed circuit board and the top of converter is connected to cooler. As module's efficiency is rather higher and its shell temperature allows 185°C, it is unnecessary to take cooling into account if the condition is inadmissible. The shell can be suspended or connected to GND. It can prevent radiation if it is connected to GND. If it is required to be suspended and prevent radiation, a 1000pF-10000pF capacitor should be connected between GND and shell.

During the use, input and output are needed to be connected with a capacitor. The capacitor requires being much closer to the module. In normal condition, 22uf~100uf is connected at input terminal and 68uf~330uf is connected at output terminal. The bigger the capacitor's capacity is, the better the performance of module's parameters will be. If the current is small in actual use, input and output capacitor can be properly lessened.

During use, if ripple is a little bit bigger for circuit, it is possible to use capacitor or LC network to filter it.

Outline Diagram

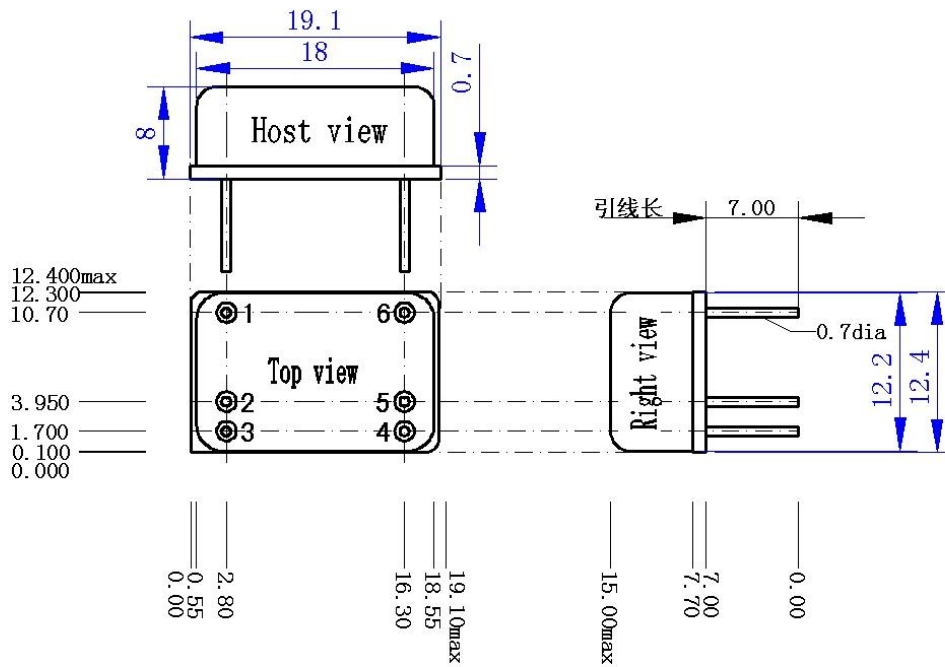

Definition of Pins

Pin No.	Output Definition
1	Input +
2	Input GND
3	EN
4	ADJ
5	Output GND
6	Output +

Product performance, reliability and information are subject to change without prior notice.

Jan 15, 2025