

FHP3 Series High-temperature DC-DC Modules

Features:

- : High operating temperature (ambient temperature: $-55^{\circ}\text{C} \sim +175^{\circ}\text{C}$ and max. shell temperature: $+185^{\circ}\text{C}$)
- : Small size (L: 25.5×W: 25.8×H: 10.8MM.)
- : High conversion efficiency (typical 85%)
- : Sealed metal casting (impact and moist resistance and electromagnetic radiation protection)
- : Wide input range (10V~20V, 18V~36V, 36V~108V, 60V~120V, 100V~200V)
- : Multi-output mode (up to dual routes: 3.3V, 5V, 5V, 9V, 12V, 15V, 24V)
- : High operating frequency (300KHZ)
- : Integrated LC EMI filter
- : Providing rated power without deduction at 175°C (shell); providing 50% of rated power at 185°C (shell)
- : Over-heat protection at 210°C



Description:

The FHP3 serial 3W high-temperature DC-DC power module is designed for the electronic equipments working in the harsh environment and can work for 2000 hours at 150°C shell temperature, 750 hours at 175°C shell temperature and 400 hours at 185°C shell temperature. With features of being resistant to high temperature, impact and humidity, it is a power supply system especially applicable to petroleum survey logging tool, petroleum drilling instrument, geophysical detecting instrument, vehicles, telecommunication, network infrastructures, enterprise and high-performance calculation. It has five optional input ranges: 10 ~ 20V, 18 ~ 36V, 36 ~ 72V, 60 ~ 120V, 100 ~ 200V and can provide fixed-voltage output in the mode of single-way, double-way, or three-way, and within the entire operating temperature range and under the condition change of full-load and no-load, the output voltage fluctuation is less than 0.3V. However, the output precision of 3.3V voltage is even less than 0.15V. The operating frequency of the FHP5 series is up to 300KHZ, which provides good wave filtration. Its output voltage ripple is less than 100MV in the conditions of no wave filtering conditions. Within the entire temperature range, the temperature stability of frequency should be $\pm 8\%$.

FHP3 series is specially designed for application with light load. Its efficiency is up to 80% when output is 2.4W and 85% when output is 3W. In order to pursue light load and high efficiency, high-low ratio of input range of circuit, unlike three times of high-low ratio in other series, drops to two times.

In order to pursue light load and high efficiency, FHP3 series gives up some protection circuit. If users get accustomed to our products of other series, please pay attention to the difference between them.

(A: No overvoltage shutoff function B: No undervoltage shutoff. If the input current drops after module normally works, the output is still normal, but input current will increase with input drops. C: No over-current shutoff but over-current protection function; D: No soft start function)

FHP3 Series contains an in-built LC network, which can effectively reduce the fluctuations of the input current and the output voltage.

FHP3 components completely pass the in-factory test in strict accordance with the enterprise standards and GJB, which includes 24 ~ 72-hour live aging and screening at $+175^{\circ}\text{C}$. All finished products have experienced 8-hour full-load operation at $+175^{\circ}\text{C}$ before delivery so as to fully expose the damage to the components during the production process and hence ensure the reliability of products.

Type selection:

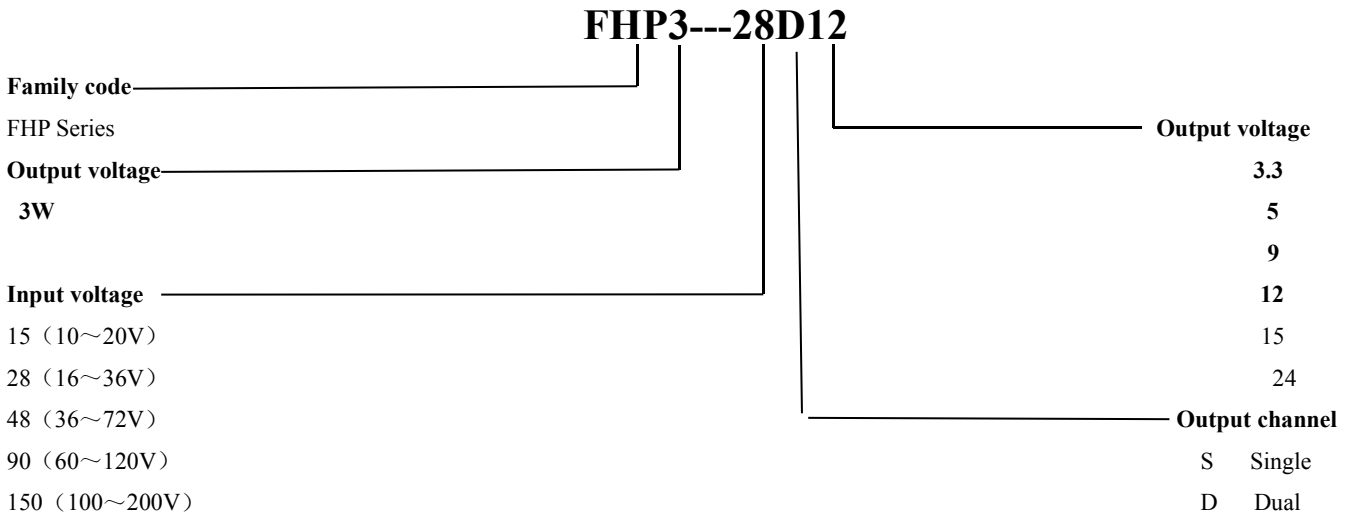

Technical parameters:

- (1) Operating temperature: -55 °C ~ +175 °C Maximum shell temperature: +185 °C.
- (2) Input voltage: 10~20V, 18~36V, 36~72V, 60~120V, 100~200V
- (3) Output voltage: as many as three-way, 3.3V, 5V, 9V, 12V, 15V, 24V
- (4) Output ripple: 100mVp-p (typical 30mVp-p)
- (5) Output power: 3W
- (6) Output accuracy: less than 5%
- (7) Load regulation: less than 5%.
- (8) Temperature stability: less than ±2.5% (typical ±1%)
- (9) Line regulation: ±0.1% (10% linear change).
- (10) Earthquake resistance: 25G, 0 ~ 300Hz
- (11) Conversion efficiency: 80% ~ 85%
- (12) Static power consumption: 0.3W Maximum
- (13) Isolation voltage between input and output or between the outputs: 1000V
- (14) Over-heat turnoff at 210°C
- (15) Mechanical dimensions: (1) L: 25.5MM × W:25.8MM × H:10.8MM

Service Requirements:

As the module is suitable for light load and has high efficiency, it does not need to add heat emitter. But from the angle of heat reliability, its service life will prolong by one times when the temperature drops 8 °C, therefore, the heat of power shell is better to be dissipated quickly to guarantee that the temperature of module's shell not above 185 °C. The module's shell is separated from input/output. In order to reduce switch spike, we use two 1000V/20000PE capacitors to respectively connect the module's shell to input/output ground wire. In some applications, it requires that input and output have common ground and it must use the shortest and roughest wire to make input and output ground wire short circuit as soon as it comes out the module. The shorter the connection distance is, the less the interference is.

For the module with single output, the output voltage remains constant with output current changing. For the module with dual output, the output voltage of primary output remains constant with output current changing, but the auxiliary output voltage changes along with the variation of its current and primary output current. For the dual routes with

symmetrical positive and negative outputs, positive output takes primary position. If positive and negative output current is symmetrical, the auxiliary output voltage remains unchanged. So long as the primary output current remains unchanged, the auxiliary output current becomes larger and the auxiliary output voltage will become lower. If the auxiliary output current remains unchanged, the primary output current will become larger and the auxiliary output voltage will become higher. Generally speaking, the range of variation is within 0.5V. Generally, the dual output is symmetry of positive and negative output, but it can be dissymmetrical too. For example, if primary output of FHP3-48S5S15 is +5V, then auxiliary output is +5V; if primary output of FHP3-48S15S5 is +15V, then auxiliary output is +5V; if primary output of FHP3-28S5S-9 is +5V, then auxiliary output is -9V.

Switch power does not permit empty load, but in order to reduce the heat source inside module, we arrange no dummy load inside module. During test and usage, attention should be paid to this point. Once module operates with empty load, the module will not work and even the filtering capacitor inside the module will be burned out. If the load is light, each output should 1MA discharge current.

Outline diagram:

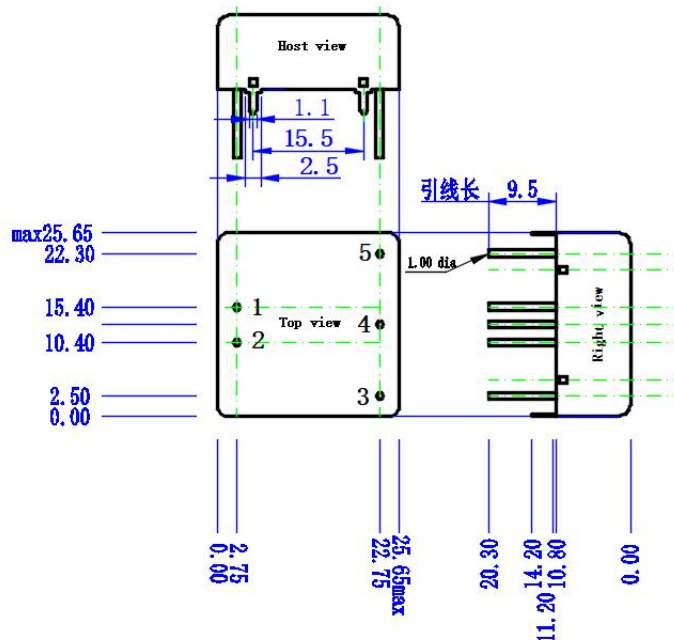

Note: 1、 The tolerance of needle diameter and between two pins is $\pm 0.1\text{mm}$;

2、 The tolerance of external dimension is $\pm 0.2\text{mm}$

Definition of pinouts:

Pin No.	Definition of single output	Definition of dual output
1	Negative input	Negative input
2	Positive input	Positive input
3	Positive output	Positive output (primary output)
4	NC	Output ground
5	Positive output	Negative output (auxiliary output)

(Product performance, reliability and information are subject to change without prior notice.)

July 12, 2023