

FHNA100 Series High-temperature AC-DC Power Converters

Features

- : Working temperature: ambient temperature: $-55^{\circ}\text{C} \sim +175^{\circ}\text{C}$ and shell temperature: $+185^{\circ}\text{C}$
- : Wide input range: AC: 180V~340V
- : Output power: 100W
- : Small size: L180.0×W:38.0×H:16.9mm
- : Output channels are up to four and four isolated output ground (12V, 15V, 18V, 24V, 36V, 48V, 72V, 100V, 150V, 200V, 250V, 300V, 400V free combination)
- : Conversion efficiency: typical 80%-90%
- : Sealed metal casting: impact and moist resistance and electromagnetic radiation protection
- : Integrated LC EMI filter
- : Provide rated power without deduction at 175°C (shell), provide 80% rated power at 185°C
- : Over-heat protection at 210°C
- : Output short-circuited or overload cut-cut protection



Description

FHNA series 100W high-temperature offline AC-DC power converters, specially designed for electronic equipment working in the harsh environment, can continuously work for 4,000 hours at shell temperature 150°C , 1,500 hours at shell temperature 175°C and 700 hours at shell temperature 185°C . With features of being resistant to high temperature, impact and humidity, it is particularly suitable for being used as power supply system for petroleum prospecting logging tool, petroleum drilling instrument, geophysical detecting instrument, vehicles, telecommunication, network infrastructures, enterprise and high-performance calculation, etc.

FHNA100 series 100W high-temperature AC-DC power converters use the latest thermal design and new semiconductor technology. The output power density is the same as the FHA100 series, but the service life is doubled. The designed output voltage includes 12V, 15V, 18V, 24V, 36V, 48V, 72V, 100V, 150V, 200V, 250V, 300V, 400V. The output can be either of them and combinations of any four voltages. MOUT is main output terminal and OUT1, OUT2 and OUT3 are auxiliary output terminals. During the use, the voltage outputted from main output terminal MOUT is most stable. The main output is isolated from the auxiliary output. The output power of the main output is required to be the largest output of the two. If the main output is greater than 36V, there can be no more than three outputs!

FHNA100 series 100W high temperature AC-DC power converters' AC input voltage range is up to AC180V ~ 340V, which is very suitable for oil logging, because the oil logging power supply cable's resistance is up to 400 ohms. The downhole cable head voltage is generally required to be 220V AC. In order to make the module output 100W power, then 0.5A current is needed by the calculation with 90% conversion efficiency. In this case, the cable will need to consume 200V voltage, which requires at least 420V ground power supply voltage to deliver 100W power down. In the actual logging, sometimes the load of the downhole equipment is not constant, which causes AC-DC module's input

voltage to change with the change of load. As the power supply voltage cannot be frequently adjusted on the ground with the change of load, which requires AC-DC module bear an AC input of 420V in extreme conditions (with the load empty).

Our FHNA100 series can only withstand 340V ac voltage at present, so we should pay close attention to the power supply current when the voltage is higher than 340V and estimate the cable head voltage of downhole power supply based on the cable situation, so as to ensure that the ac input does not exceed 340V.

The mechanical dimensions of the FHNA100 are particularly suitable for small hole exploration in petroleum logging.

The temperature resistance of all components adopted by FHNA100 is above +200°C. With the currently best thermal design, the temperature of elements and casing only rises by 9°C in the condition with good heat radiation, thus it is able to steadily work at ambient temperature +175°C for a long time. But when temperature of chip exceeds +204°C, overheat protection circuit of chip will be activated and it begins to reduce output power until zero at +210°C. When temperature lagged to +195°C, overheat protection circuit will rest and converter begins to output power again.

FHNA100 is able to work with full load when casing temperature is less than +175°C and work with 80% of load at casing temperature +185°C. At ambient temperature +175°C, casing temperature will still reach 180°C even if good heat radiation is adopted. For this reason, it is suggested to avoid working with full load at ambient temperature above +170°C. 80% of load at most.

The voltage and ripple wave outputted from main output terminal do not vary with the variation of itself and power of auxiliary output voltage. In the condition that power outputted from main output terminal is constant, the voltage of auxiliary output terminal OUT decrease by 2% at most with the rise of its output power. If power outputted from auxiliary output terminal OUT is constant, their output voltage increases with the increase of power outputted from main output terminal. For this feature, the main and auxiliary output should be specified in using and selecting types. If the model is FHNA100-220S12-S24, it will output dual-way mutually isolated voltages 12V and 24V, in which 12V is from MOUT, 24V from OUT1. That is our model FHNA100-ACINSMOUT-SOUT1-SOUT2-SOUT3.

In using multiple outputs, if the power of an output (main or auxiliary) dynamically changes, it will cause the auxiliary output voltage to fluctuate accordingly. If the fluctuation is big, measures must be taken. The voltage fluctuation above 0.5% appears when output power varies between the rated power of above 10% and below 70%. Thus, when an output power (main or auxiliary) varies between the rated power of above 10% and below 70%, its voltage fluctuation generally is less than 0.5% of output voltage. This fluctuation is free from consideration in general at the time. If the output power varies between the range of rated power of less than 10% and above 70%, the higher the proportion of high and low output power, the greater the fluctuation. And the fluctuation frequency is equal to the frequency of power change. Then, the secondary filtering is thus considered to be done. If the fluctuation frequency of power is greater than 10KHz, the simple filtering is able to remove the fluctuation. If the fluctuation frequency of power is less

than 10KHz, there will be trouble in filtering. Then it is necessary to reduce the number of output ways of main converter and add secondary DC/DC converter to re-convert additional voltage.

If the auxiliary output voltage accuracy requires high, the voltage requires very stable, or the voltage is less than 12V, it is better to choose our switching regulator FHB series for voltage regulation and conversion.

If the number of required to output voltage is more than four outputs, for non-isolated channels between the outputs, OUT* is output by the FHNA100 first, and FHB series is selected to connect with OUT* for conversion output. If the isolated channels of output voltage is greater than four, then the FHNA100 selects OUT* to output 24V , 36V, 48V or 72V, and DC/DC with input of 28V (16~48V), 48V (24~72V) or 50V (36~108V) and switching regulator FHB module are connected following OUT1 for secondary conversion.

FHNA100 series converter contains the LC network, which can effectively reduce input current and output voltage fluctuation.

FHNA100 series converter contains the output short circuit and overload automatic turn-off circuit. When the output lasts for 0.1s and exceeds 120% of the rated output power, the converter cuts off all outputs. After the over-current fault is eliminated, it automatically resumes the output voltage. If the overload duration of output is less than 0.1s, the converter will not act.

Key components used for FHNA100 have completely passed the factory test in accordance with the national military product quality standard. The factory test includes 24~72-hour live aging and screening under the temperature of +175℃ . All finished products have experienced 8-hour full-load operation under the temperature of +175℃ before delivery so as to fully check the damage to the elements during the production process and hence ensure the reliability of products.

Type Selection

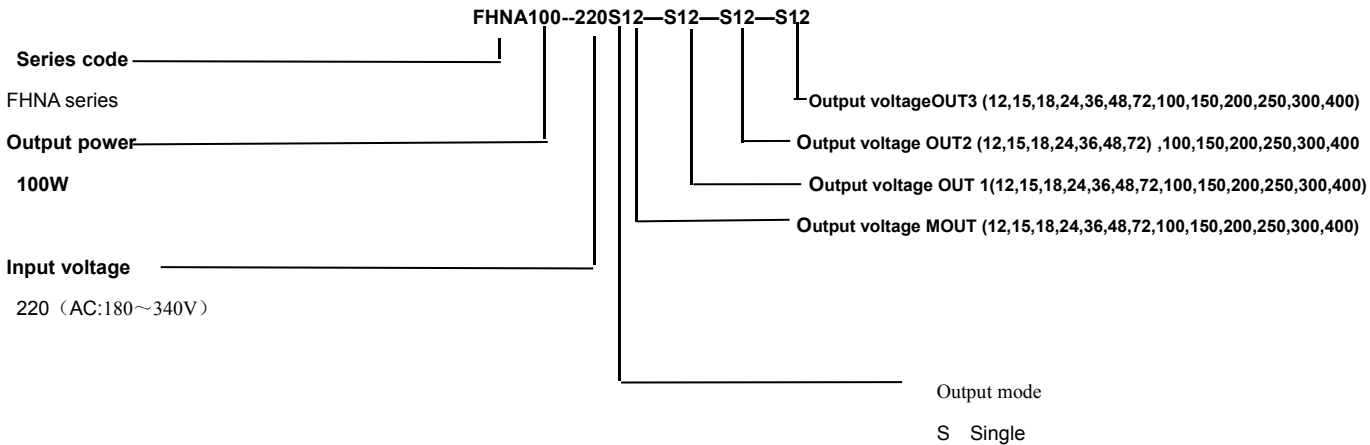

Note: — means isolation. If it is single output, there is no —SOUT1—SOUT2 —SOUT3

Example: the model FHNA100-220S15-S36, MOUT outputs 15V and OUT1 outputs 36V

Technical Data

- (1) Operating temperature: $-55^{\circ}\text{C} \sim +175^{\circ}\text{C}$, Max. shell temperature: $+185^{\circ}\text{C}$.
- (2) Input voltage: AC: 180V~340V
- (3) Input AC frequency: 50Hz~400Hz
- (4) Output voltage: up to two output channels, and two isolated output ground circuits:
12,15,18,24,36,48,72,100,150,200,250,300,400 (free combination)
- (5) Output ripple: Less than 0.5% of output voltage
- (6) Output power: 100W
- (7) Temperature stability: Less than $\pm 2.5\%$, typical $\pm 1\%$
- (8) Shock resistance: 25G, 0 ~ 300Hz
- (9) Conversion efficiency: 80-90%
- (10) Static power consumption: 1.5W Max.
- (11) Dimension: L: 180.0×W:38.0×H:16.9mm
- (12) Isolation voltage between input and output: 1000V
- (13) Output form of voltage: lead wire

Service Requirement

As the power converter has nearly 15W power consumption under the condition of full-load operation and its size are small, good medium is necessary to be added between the shell of the power converter and the radiator so as to ensure the temperature of the converter shell to be less than 185°C .

The shell of the converter is isolated from the input and output. During the use, the converter is usually mounted on instrument or its framework with the framework as a radiator. If the ripple cannot be filtered with capacitance or LC network, then this ripple is electro-magnetic interference (EMI). Thus, an EMI filtering converter is necessary to be added to input and output terminals of FHV10. To function properly, the shell of filtering converter should be suspended not to connect with radiator, input and output ground wires. If it is connected to either of them, EMI filtering converter will not function properly. As we have added EMI network to input and output terminals inside converter, so long as the shell is suspended, it will function. If the ripple is still large, it is needed to externally connect input or output EMI filter outside the shell. To suspend shell, it usually puts heat-conducting pad, ceramics backing or silicon rubber pad between the shell and radiator. If the ripple is still large after the internal EMI functions, it is necessary to connect input or output EMI filtering outside the converter.

Outline Diagram

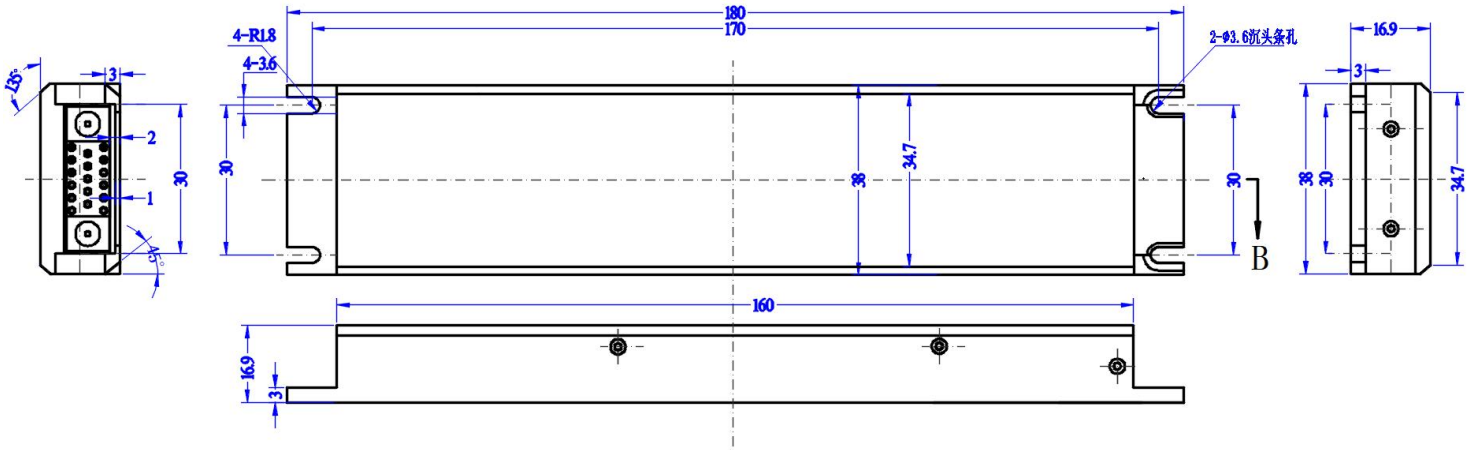

- Note: 1、 Mounting hole and mounting hole spacing dimension is $\pm 0.1\text{mm}$
2、 The tolerance of external dimension is $\pm 0.2\text{mm}$

Product performance, reliability and information are subject to change without prior notice.

June 11, 2022