

FHP18 Series Multiple Isolated-output High-temperature DC-DC Power Converters

Features:

- : Working temperature: Ambient temperature:
-55°C ~ +175°C, max. shell temperature up to +185°C
- : Output power: 18W
- : Size: L62.0×W23.0×H12mm
- : Multiple outputs up to 4 and max. 3 isolated output ground circuits (3.3V, 5V, 7V, 9V, 12V, 15V, 18V, 24V, 36V, 48V)
- : Output ripple: Maximum 100mV, typical 50mV
- : Conversion efficiency: Typical 75-85%
- : Input range: DC: 16V ~ 48V, 24V ~ 72V, 36 ~ 108V, 70 ~ 210V, 120 ~ 360V
- : Sealed metal casting: Impact and moist resistance and electromagnetic radiation protection
 - : Integrated LC EMI filter
 - : Provide rated power without deduction at 175°C (shell); provide 80% rated power at 185°C (shell)
 - : Over-heat protection at 210°C
 - : Output short circuit and overload cutoff protection



Description:

FHP18 series 18W multiple outputs isolated high-temperature DC-DC power converters, specially designed for electronic equipment working in the harsh environment, can work for 2,000 hours at shell temperature 150 °C, for 750 hours at shell temperature 175 °C and for 400 hours at shell temperature 200 °C. With features of being resistant to high temperature, impact and humidity, it is particularly suitable for being used as power supply for petroleum prospecting logging tool, petroleum drilling instrument, geophysical detecting instrument, vehicles, telecommunication, network infrastructures, enterprise and high-performance calculation, etc. It has five alternative input ranges including 16 ~ 48V, 24 ~ 72V, 36 ~ 108V, 70 ~ 210V and 120 ~ 360V and is able to provide at most 4 outputs and 3 isolated ground circuits. They are allowed to be connected to form output combinations of different types as per requirement. Within the entire temperature range and conversion between full load and no-load, the output voltage fluctuation is within 2%.

The output voltage designed for FHP18 series 18W multiple isolated-output high-temperature DC-DC power converters include 3.3V, 5V, 7V, 9V, 12V, 15V, 18V, 24V, 36V and 48V. The output can be either of them and combinations of any two, three or four voltages. MOUT represents the main output terminal, OUT1 and OUT2 represents the auxiliary output terminals. During the use, the voltage output by MOUT is the most stable and the main output voltage is generally symmetric of positive and negative, and it allows one output or two symmetric outputs. Main outputs are not isolated but outputs between MOUT and OUT1 or OUT2 and between OUT1 and OUT2 are isolated. Given that main output is symmetric of positive and negative, the positive and negative output will sample feedback regulated voltage which should be greater than or equal to 3.3V. Given that positive and negative outputs of main output

are not symmetric, one samples 80% of feedback regulated voltage and the other samples 20% of feedback regulated voltage. There must be one output voltage that is greater than 5V. The output power of main output is required to be the highest among that of four outputs.

Main output voltage and ripple do not vary with the variation of itself and auxiliary output. With the precondition that MOUT outputs constant power, the voltage of auxiliary output terminals OUT1 and OUT2 drops at 2% max. with the rise of their output power. If auxiliary output terminals OUT1 and OUT2 output constant power, their output voltage will rise with the rise of power output by MOUT. For this feature, the output should be specified in using and selecting types. If the model is FH18-150S12-S24-S5, it will output three mutually isolated voltages 12V, 24V, and 5, of which, 12V is from MOUT, 24V from OUT1 and 5V from OUT2. That is our model FHP18-DCINSMOUT-SOUT1-SOUT2.

In the course of using multi-output converter, if the output (main or auxiliary) of an output dynamically changes, it will cause the auxiliary output voltage to fluctuate accordingly. If the fluctuation is greater than 50mA, measures must be taken. The voltage fluctuation above 50mA appears when output power varies between the rated power of above 10% and below 70%. The fluctuation increases along with the rise of proportion of high and low output power. The fluctuation frequency is equal to the frequency of power variation. At this time, the secondary filtering is thus considered to be done. If the fluctuation frequency of power is less than 10KHz, there will be trouble in filtering. Then it is necessary to reduce the number of output channels of main converter and add secondary DC/DC converter to re-convert additional voltage. If the fluctuation frequency of power is greater than 10KHz, the simple filtering is able to remove the fluctuation.

In the course of operation, when an output power (main or auxiliary) varies between the rated power of above 10% and below 70%, its voltage fluctuation generally is less than 50mV. This fluctuation is free from consideration in general.

Our design concept is that if the required output voltage is above four channels, then FH18 chooses OUT2 to output 24V, 36V and 48V. Following OUT2, connect our DC/DC converter with input voltage of 28V(16~48V) or 48V(24~72V) to conduct secondary conversion.

FHP18 series power-supply converter adopts working frequency 300KHz/150KHz. Input voltages 16V~48V, 24V~72V and 36~108V adopt frequency 300KHz and input voltages 70~210V and 120~360V adopt frequency 150KHz. Both of them can pass various EMI standard tests. In the condition without adding any filtering, its output voltage ripple is less than 50mV. The temperature stability of frequency within the entire range of temperature is $\pm 8\%$.

FHP18 series power-supply converter contains an in-built LC network, which can effectively reduce the fluctuations of the input current and the output voltage.

FHP18 series power-supply converter contains the output short circuit and overload automatic turn-off circuit. When the output lasts 0.1s and exceeds 120% of the rated output power, the converter cuts off all outputs. After the over-current fault is eliminated, it automatically enters soft-start mode and restores the output voltage. If the overload duration of output is less than 0.1s, the converter will not act.

Key components used for FHP18 series power-supply converter are purchased in military level and completely pass the in-factory test in strict accordance with the national military product quality standard. The factory test includes 24~72-hour live aging and screening under the temperature of $+175^{\circ}\text{C}$. All finished products have experienced 8-hour full-load operation under the temperature of $+185^{\circ}\text{C}$ before delivery so as to fully check the damage to the components during the production process and hence ensure the reliability of products.

Type Selection:

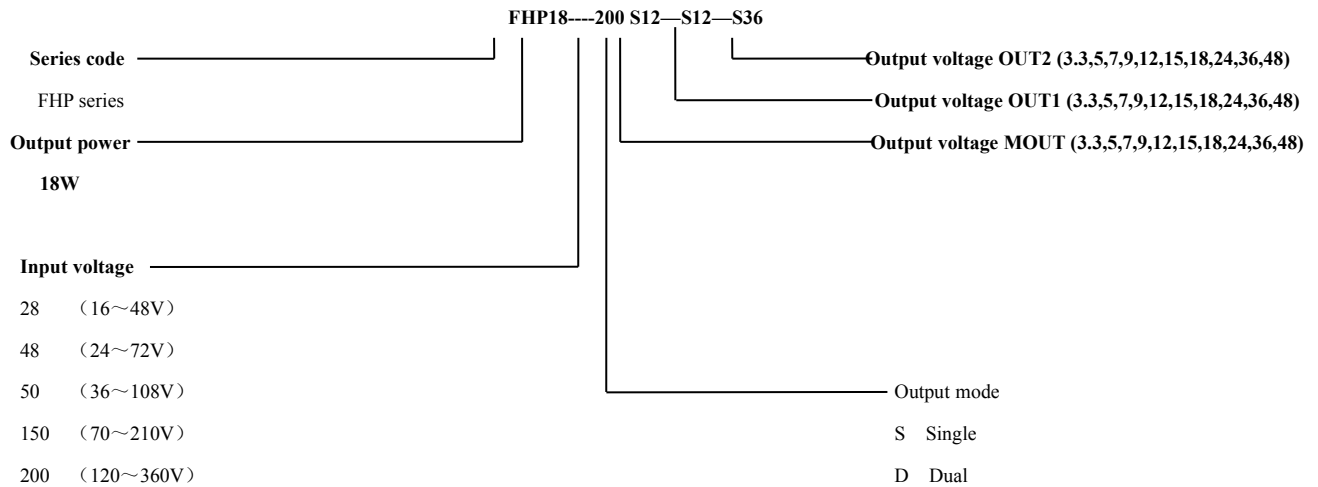

NOTE: “—” in model refers to the meaning of isolation. If the single output is adopted, there is no—SOUT1—SOUT2; if dual output is adopted, there is no—SOUT2.

Model sample: For FHP18-150D15-S5-S36, MOUT outputs $\pm 15V$, OUT1 outputs 5V and OUT2 outputs 36V!; for FHP18-50S15S3.3-S5-S12, MOUT outputs +15V and +3.3V, OUT1 outputs 5V and OUT2 outputs 12V! In the condition that MOUT has two outputs, when converter stably outputs voltage, feedback sample takes 80% of front voltage and 20% of back voltage. For example, model FHP18-50S15S3.3-S5-S12 regulates voltage +15V and +3.3V, +15V regulates 80% and +3.3V regulates 20%.

Technical Parameters:

- (1) Operating temperature: $-55^{\circ}\text{C} \sim +175^{\circ}\text{C}$, Max. shell temperature: $+185^{\circ}\text{C}$.
- (2) Input voltage: 16V~48V, 24V~72V, 36~108V, 70~210V, 120~360V
- (3) Output voltage: Multiple outputs up to 4 outputs and at most 3 mutually-isolated output ground circuits:
Free combination of 3.3V, 5V, 7V, 9V, 12V, 15V, 18V, 24V, 36V, 48V
- (4) Output ripple: Less than 100mVp-p (typical 50mVp-p)
- (5) Output power: 18W
- (6) Temperature stability: Less than $\pm 2.5\%$ (typical $\pm 1\%$)
- (7) Shock resistance: 25G, 0 ~ 300Hz
- (8) Conversion efficiency: 75-85%
- (9) Static power consumption: 0.8W Max.
- (10) Dimension: L62.0×W23.0×H12.0mm
- (11) Isolation voltage between input and output: 1000V
- (12) Output form of voltage: DIP pin

Service Requirement:

As the power converter has nearly 6W power consumption under the condition of full-load operation and its size are small, good medium is necessary to be added between the shell of the power converter and the radiator so as to ensure the temperature of the converter shell to be less than 185°C .

The shell of the converter is isolated from the input and output. During the use, the converter is usually mounted on instrument or its framework with the framework as a radiator. If the ripple cannot be filtered with capacitance or LC network, then this ripple is electro-magnetic interference (EMI). Thus, an EMI filtering converter is necessary to be added to input and output terminals of FHP18. To function properly, the shell of filtering converter should be suspended not to connect with radiator, input and output ground wires. If it is connected to either of them, EMI filtering converter will not function properly. As we have added EMI network to input and output terminals inside converter, so long as the shell is

suspended, it will function. If the ripple is still large, it is needed to externally connect input or output EMI filter outside the shell. To suspend shell, it usually puts heat-conducting pad, ceramics backing or silicon rubber pad between the shell and radiator. If the ripple is still large after the internal EMI functions, it is necessary to connect input or output EMI filtering outside the converter.

Input and output of the converter at most have four ground wires and if they are needed to be connected together, connection should be done at the point less than 1cm where the lead wires go out of the converter. The closer that wire at connection point is to the converter, the less the intervention will be.

Outline Diagram:

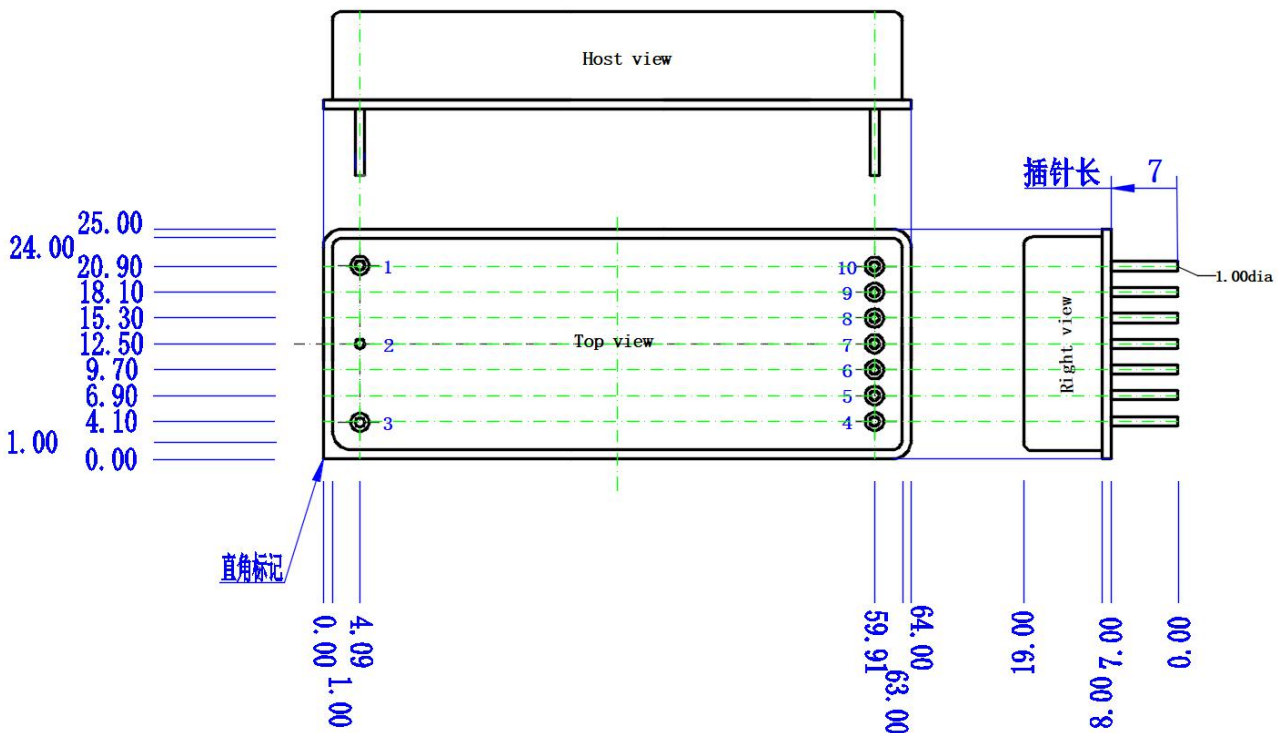

- Note: 1、 The tolerance of needle diameter and between two pins is $\pm 0.1\text{mm}$;
- 2、 The tolerance of external dimension is $\pm 0.2\text{mm}$

Definition of Pins:

Pin No.	Definition of single output	Definition of two-output	Definition of three-output	Definition of four-output
1	Input +	Input +	Input +	Input +
2	Connected to shell	Connected to shell	Connected to shell	Connected to shell
3	Input -	Input -	Input -	Input -
4	MOUT	MOUT	MOUT	MOUT1
5	MOUT	MOUT	MGND	MGND
6	MOUT	MGND	MOUT	MOUT2
7	Null	MGND	OUT 1	OUT 1
8	MGND	OUT 1	GND 1	GND 1
9	MGND	OUT 1	OUT 2	OUT 2
10	MGND	GND 1	GND 2	GND 2

Product performance, reliability and information are subject to change without prior notice.
June 11,2022